



[MÉXICO]
**ANTES DE DEVOLVER EL
 PRODUCTO A LA TIENDA:**

**Comuníquese Con Servicio Al
 Cliente De Huffy. Nos Complace
 Ayudarlo Con Cualquier Parte
 O Problema De Ensamblado
 Que Pudiera Tener.**

Para obtener Servicio al cliente
 rápido, visite:

<http://www.huffybikes.com/>
 O LLAME AL TEL: 01800 1483 391
 (Mexico only)

Para comunicarse por correo electrónico:
servicio@huffymex.com

<http://www.huffybikes.com/home/globalcontact>

for current contact information
 para obtener la información de contacto actual
 pour les informations de contact actuelles

**For Assembly Help:
 Ayuda de la Asamblea:
 Aide à l'assemblage:**

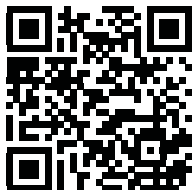

[In the US and Canada]
PLEASE - BEFORE RETURNING TO STORE:

**Contact Huffy Customer Service. We
 are glad to assist you with any parts or
 assembly problems you might have!**

~
**VEUILLEZ NOTER : AVANT DE
 RETOURNER AU MAGASIN :**

**Communiquez Avec Le Service À La
 Clientèle De Huffy. Nous Vous Aiderons
 Volontiers Avec Tout Problème Concernant
 Les Pièces Ou Le Montage!**

For Fast Customer Service, go to:
 Pour un Service à la clientèle rapide, allez sur le site :
<http://www.huffybikes.com/contact>

To Order Parts (US), go to:
 Pour obtenir des pièces (CANADA), allez à:
<http://www.huffybikes.com/parts>
OR TEL: 1 800 872 2453 (US only)
OU appelez le 1 800 872 2453 (CANADA seulement)

For email, go to <http://www.huffybikes.com/contact>
 Pour communiquer par courriel huffycanada@huffy.com

H-Tri_STOP-Global_010318_i0388

HUFFY
 © Copyright Huffy Corporation 2018

Date Code Label
 Here

Owner's Manual Battery Ride-On Bubble Scooter

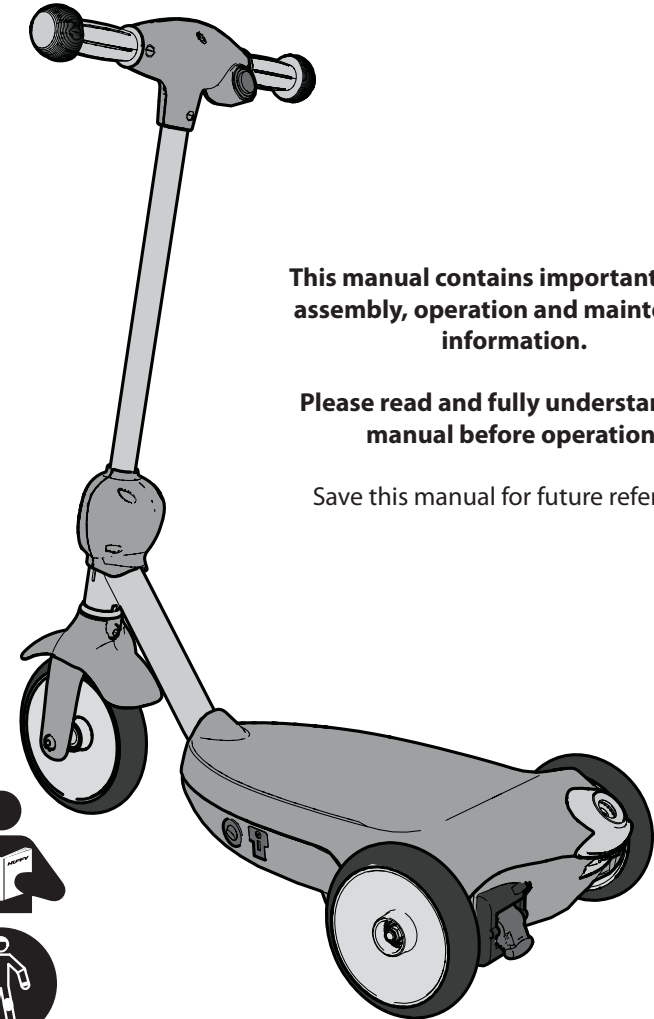

**This manual contains important safety,
 assembly, operation and maintenance
 information.**

**Please read and fully understand this
 manual before operation.**

Save this manual for future reference.



**See back page for Customer Service Information
 Consultez el reverso para Servicio de Información al Cliente
 Voir pages verso pour des renseignements le service à la Clientèle**



Owner's Manual Index

Safety

- User and Battery Warnings.....3-4
- Radio Frequency4
- Charging Drive Motor Warnings.....5

Assembly

- Parts Assembly.....6-7
- Introduction to Assembly and Tools Needed8
- Charging Port Location.....8
- Vehicle Assembly9-11

Operation

- How to Operate your Vehicle.....12

Maintenance Repair and Service

- General13
- Battery Replacement, Storage and Disposal.....14
- Drive Motor and Battery Fuse15
- Battery Recharge Time15

Troubleshooting 16-17

Warranty

- Limited Warranty.....18

Contact Information..... Back Cover

WARNING:

- CHOKING HAZARD: Small parts. Not for children under 3 years. Keep small children away when assembling.
- To reduce the risk of injury, adult supervision is required.
- Never use in roadways, near motor vehicles, on or near steep inclines or steps, swimming pools or other bodies of water; always wear shoes, and never allow more than one rider.
- The user must be **3-5 years**, and weigh no more than **50 lbs (23kgs)**.



IMPORTANT! Before using the unit for the first time the battery needs to be charged for at least **8 to 12** hours - no more than **20** hours. Only an adult who has read and understands the safety warnings should handle, charge or recharge the battery (see Maintenance).

Limited Warranty - US

General:

Part or model specifications are subject to change without notice.

This Limited Warranty is the only warranty for the product. ALL WARRANTIES OTHER THAN STATED HEREIN ARE DISCLAIMED INCLUDING IMPLIED WARRANTIES OF MERCHANTABILITY AND FITNESS FOR A PARTICULAR PURPOSE, TO THE EXTENT ALLOWABLE BY APPLICABLE LAW. ALL LIABILITY FOR INCIDENTAL, PUNITIVE, SPECIAL, OR CONSEQUENTIAL DAMAGES ARE EXPRESSLY DISCLAIMED, TO THE EXTENT ALLOWABLE BY APPLICABLE LAW.

The only uses for this product are described in this manual.

Warranty registration is not required.

The Limited Warranty extends only to the original consumer and is not transferable to anyone else.

What does this Limited Warranty cover?

This Limited Warranty covers defects in workmanship and materials for all parts of the product except those indicated below as not warranted.

What must you do to keep the Limited Warranty in effect?

This Limited Warranty is effective only if:

- Product is completely and correctly assembled.
- Product is used under normal conditions for its intended purpose (see the following section for excluded activities).
- Product receives all necessary maintenance and adjustments.
- Product is used for general transportation and recreational use only.

What is not covered by this Limited Warranty?

This product is designed for recreational use only. This Limited Warranty does not cover normal wear and tear, normal maintenance items, or any damage, failure, or loss that is caused by improper assembly, maintenance, adjustment, storage, or use of the product. This Limited Warranty does not extend to future performance.

This Limited Warranty will be void if the product is ever:

- Used in any competitive sport
- Used for stunt riding, jumping, aerobatics or similar activity
- Modified in any way

- Modified with the addition of a motor
- Ridden by more than one person at a time
- Rented, sold, or given away
- Used in a manner contrary to the instructions and warnings in this Owner's Manual

What will The Manufacturer do?

Manufacturer's sole and exclusive obligation under this Limited Warranty is to repair and/or replace, at its sole option, any covered defect in workmanship or materials.

How do you get service?

- Contact the Customer Service Department.
- See included list for Customer Contact information.

What rights do you have?

This Limited Warranty gives you specific legal rights. You may also have other rights which vary from State to State.

For how long does this Limited Warranty last?

- When used in this Limited Warranty, the phrase "for life" means for as long as the original consumer owns the product.
- Drive Battery - 90 days
- Electronics - 90 days
- All other Components - 6 months

! WARNING: TO AVOID SERIOUS INJURY:

- It is the responsibility of the adult to educate the child and determine if they are capable of operating the vehicle safely.
- Before using the vehicle the child must understand the controls and safety issues. They must also demonstrate the capability and skill to handle the vehicle and operate its controls to avoid falls or collisions.
- After complete assembly, remove and dispose of all protective material and poly bags. Keep poly bags away from child. Be sure to remove all packaging materials and parts from underneath the vehicle body.
- Ensure child uses common sense and safe practices when using the vehicle.
- **All of these safety rules and guidelines must be followed or serious injury or death may occur to the user:**
- **Adult assembly required.** Choking hazard to children under the age of 3 years - contains small parts. Keep small children away when assembling.
- **To reduce the risk of injury, adult supervision is required. Never use in roadways, near motor vehicles, on or near steep inclines or steps, swimming pools or other bodies of water; always wear shoes, and never allow more than one (1) rider.**
- **RISK OF FIRE. Do not bypass fuse. Replace only with size and type.**
- Continuous adult supervision required while using the vehicle.
- Riders should always wear a properly fitted helmet that complies with U.S. Consumer Product Safety Commission (CPSC) Standard 16 CFR 1203.
- Body parts such as hands, legs, hair and clothing can get caught in moving parts. Never place a body part near a moving part or wear loose clothing while using the vehicle.
- Always use vehicle in a safe, secure environment on flat, smooth paved surfaces only.
- **Do not use the vehicle in an unsafe manner or at an unsafe speed.**
- **Examples include but are not limited to:**
 - Do not pull or push the vehicle with another vehicle or similar device.
 - Do not tow anything behind the vehicle.
 - Do not drive into fixed objects, which may cause the wheels to spin, causing the motor to overheat.
 - Never use near streets, water, swimming pools, hills, steps, drop-offs, sloped surfaces or driveways, wet areas, flammable vapors, in alleys, at night or in the dark.
 - Do not use the vehicle in unsafe conditions such as snow, rain, loose dirt, mud sand or fine gravel. This may result in unexpected action such as tip over and skidding. Using the vehicle in loose dirt, mud, sand, or fine gravel may damage the electronics and gear box inside the vehicle.
- **Vehicle Cautions:** Do not overload the vehicle. Do not drive in very hot weather, components may overheat. Do not allow water or other liquids to come in contact with the battery or other electric components. Do not tamper with the electrical system. Doing so may create a short, causing the fuse to trip or other damage including fire.
- There are additional hazards of using the vehicle in areas other than private grounds.
- **THIS VEHICLE HAS NO BRAKE.** When engaged, motor friction will gradually stop the unit.

This product meets ASTM F963 and CPSIA requirements for electric vehicles.

Helmet Warning Information

**! WARNING:
ALWAYS WEAR YOUR HELMET
WHEN RIDING THIS PRODUCT!**

- Helmet should sit level on your head and low on your forehead. Exposed forehead can result in serious injury.
- Adjust the strap sliders below the ear on both sides.
- Buckle the chin strap. Adjust strap until it is snug.
- No more than two fingers should fit between the strap and your chin.
- A proper fitting helmet should be comfortable and not rock forward/backward or side to side.

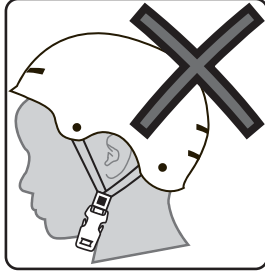
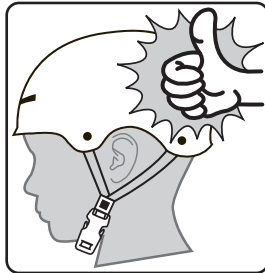

Radio Frequency Information (charger/adaptor/controller)

! WARNING: Changes or modifications to this unit not expressly approved by the party responsible for compliance could void the user's authority to operate the equipment.

This device complies with Part 15 of the FCC Rules. Operation is subject to the following two conditions:

(1) this device may not cause harmful interference, and (2) this device must accept any interference received, including interference that may cause undesired operation.

NOTE: This equipment has been tested and found to comply with the limits for a Class B digital device, pursuant to Part 15 of the FCC Rules. These limits are designed to provide reasonable protection against harmful interference in a residential installation. This equipment generates, uses and can radiate

radio frequency energy and, if not installed and used in accordance with the instructions, may cause harmful interference to radio communications.

However, there is no guarantee that interference will not occur in a particular installation. If this equipment does cause harmful interference to radio or television reception, which can be determined by turning the equipment off and on, the user is encouraged to try to correct the interference by one or more of the following measures:

- Reorient or relocate the receiving antenna.
- Increase the separation between the equipment and receiver.
- Connect the equipment into an outlet on a circuit different from that to which the receiver is connected.
- Consult the dealer or an experienced radio/TV technician for help.

Troubleshooting Guide - continued

Problem	Possible Cause	Solution
Battery will not recharge	Battery connector or adapter connector is loose	Check that the battery connectors are firmly plugged into each other.
	Charger not plugged in	
	Charger is not working	Check that the battery charger is plugged into a working wall outlet.
	Battery is dead	Replace battery.
Charger feels warm when recharging	This is normal and not a cause for concern	If excessively hot, unplug and replace.

BEFORE YOU CALL SUPPORT:

1. What is the model and date code?
2. When was the product purchased?
3. Has the product ever worked for a time or has never worked at all since purchase?
 - Yes, When did the product last operate correctly?
 - No, were the battery wires connected?
4. How long was the battery charged?
5. Is the charger plugged into the unit when you try to operate the product?
 - (The unit will not operate with charger plugged in)
6. Do any lights or sounds come on when you power the product on?
 - Yes, Does the lights and sounds go away when you press the drive switch?
7. When you press the drive switch, does an electric motor start?
 - Yes, Did you check that the correct drive wheel was installed?
 - Yes, Does the insert in the gearbox rotate?

Troubleshooting Bubble Blower:

Problem	Possible Cause	Solution
Not producing Bubbles:	Power Switch OFF	Ensure Power Switch is ON
	Bubble Solution empty	Fill Bubble Solution Tray
	Bubble Outlet clogged	Clean Outlet with water and cotton swab Run clear water through Bubble Solution Tray until system is clean.
	Bubble Motor not running.	Contact Customer Service.

SEE OPERATION SECTION FOR OPERATING INSTRUCTIONS

Troubleshooting Guide

The following are examples of potential problems. Completely read through this manual and the troubleshooting guide table before calling. If you still need help resolving the problem please contact Customer Service.

NOTE: Vehicle should be turned off and fully charged before doing troubleshooting.

Problem	Possible Cause	Solution
Vehicle does not run when switch is activated	Battery wires not connected or are loose	Connect battery wires according to assembly instructions, Check that the battery connectors are firmly plugged into each other. If wires are loose around the motor call Customer Service.
	Battery low on power	Recharge battery (see Battery: Recharge interval and time)
	Battery Charger still plugged in	Unplug Battery Charger from unit and wall in
	Thermal fuse has tripped	Let Fuse reset
	Battery is dead	Replace battery (see Battery: Replacement and Disposal)
	Electrical system or motor is damaged	Call Customer Service.
	“Dead Spot” on motor	A dead spot means the electric power is not being delivered to the terminal connection and the vehicle needs repair. Call Customer Service.
Vehicle does not run very long or runs sluggishly	Battery is undercharged.	Check that the battery connectors are firmly plugged into each other when recharging (see Battery: Recharge interval and Time)
	Battery is old and cannot be fully charged	Replace battery (see Battery: Replacement and Disposal)
	Battery low on power	Recharge battery (see Battery: Replacement and Disposal)
	Battery is old and cannot be fully charged	Replace battery (see Battery: Replacement and Disposal)
	Vehicle is overloaded	Reduce weight on vehicle (see user requirements and Safety Warnings)
	Vehicle is being used in harsh conditions	Avoid using vehicle in harsh conditions (see User Requirements and Safety Warnings)
Vehicle makes loud noise when in use	Chain is dry (on chain drive models)	Lubricate chain with light oil.
Loud grinding or clicking noises coming from motor or gear box	Motor or gears are damaged	Call Customer Service.
	Drive Wheel is partially engaged	Check drive wheel - to motor engagement.

BATTERY & CHARGER WARNINGS:



The following safety hazards may result in serious injury or death to the user of the vehicle:

- Battery Charger for Indoor use only.
- Use of a battery or charger other than the supplied rechargeable battery and charger may cause a fire or explosion. Only use the supplied rechargeable battery (or lead-acid or lithium suitable replacement) and charger with the vehicle.
- Using the rechargeable battery and charger for any other product may result in overheating, fire or explosion. Never use the rechargeable battery and charger with another product.
- Explosive gases are created during charging. Charge the battery in a well ventilated area. Do not charge the battery near heat or flammable materials.
- Contact between the positive and negative terminals may result in fire or explosion. Avoid direct contact between the terminals. Picking up the battery by the wires or charger can cause damage to the battery and may result in a fire. Always pick up the battery by its case or handles.
- Battery must be handled by adults only. Liquids on the battery may cause fire or electric shock. Always keep all liquids away from the battery and keep the battery dry.
 - Contact or exposure to battery leakage (lead acid) may cause serious injury. If contact or exposure occurs immediately call your physician. If the chemical is on the skin or in the eyes, flush with cool water for 15 minutes. If the chemical was swallowed, immediately give the person water or milk. Do not give water or milk if the patient is vomiting or has a decreased level of alertness. Do not induce vomiting.
- Battery Posts, terminals and related accessories contain lead and lead compounds (acid), chemicals known to cause cancer, reproductive harm and are toxic and corrosive. Never open the battery.
- Tampering or modifying the electric circuit system may cause a shock, fire or explosion and permanently damage the system. Exposed wiring and circuitry in the charger may cause electric shock. Always keep the charger housing closed.
- Non-rechargeable batteries are not to be recharged
- Batteries are to be inserted with the correct polarity
- The supply terminals are not to be short-circuited
- Batteries are only to be charged by adults or by children at least 8 years old
- The battery chargers used with the toy are to be regularly examined for damage to the cord, plug, enclosure and other parts, and in the event of such damage, they must not be used until the damage has been repaired.

NOTE: It is not necessary to remove the battery from the vehicle for charging.

IMPORTANT! Before using the unit for the first time the battery needs to be charged for **8 to 12 hours - never longer than 20 hours**, Only an adult who has read and understands the safety warnings should handle, charge or recharge of the battery.

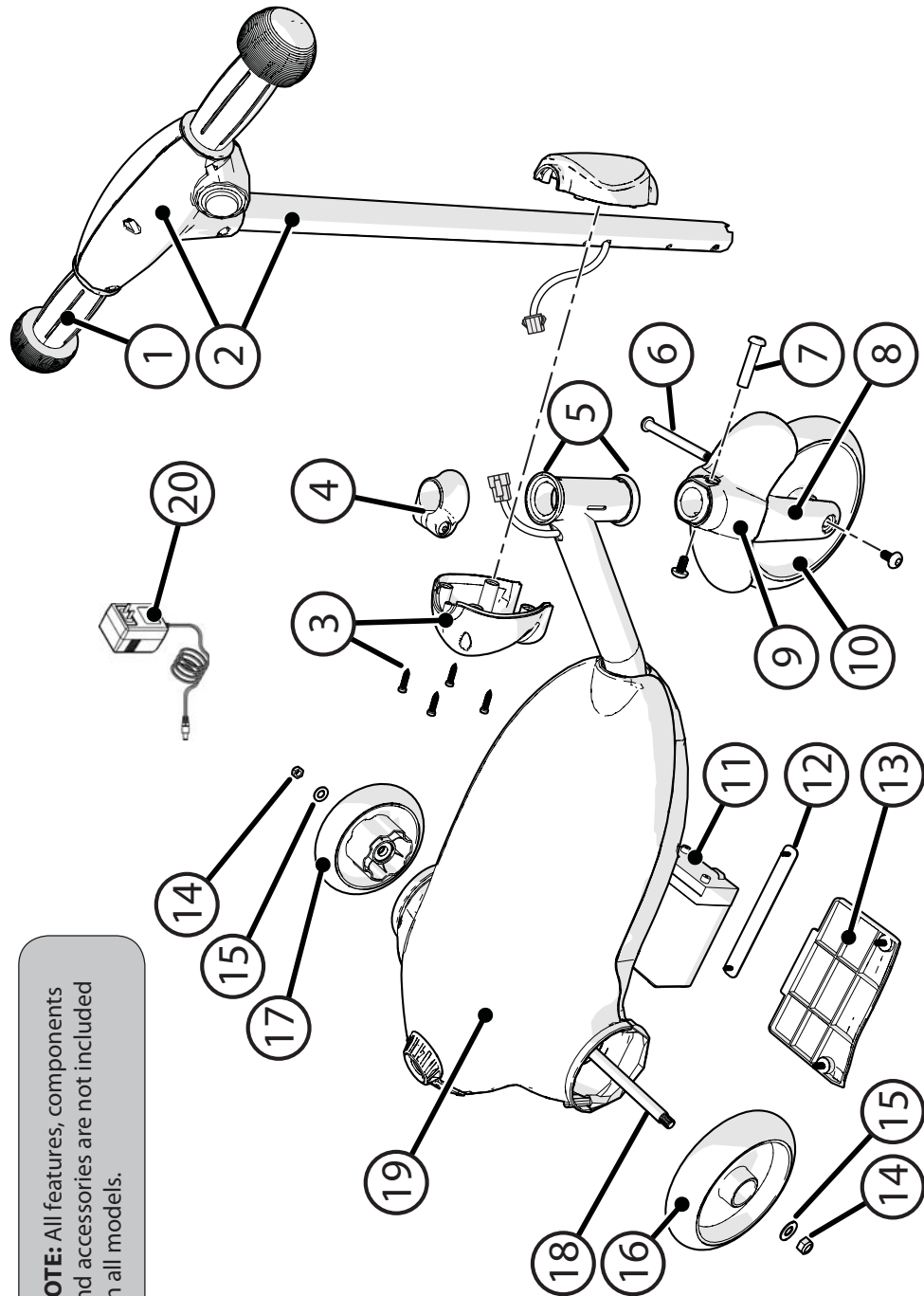

NOTE: All features, components and accessories are not included on all models.

Drive Motor Battery

Only an adult who has read and understands the safety warnings should handle, charge or recharge the battery. Failure to comply with all safety warnings may result in serious injury or death.

Battery Fuse

The drive motor circuit features a thermal fuse that will automatically trip and cut all power to the vehicle if the motor, electric system or battery is overloaded. The fuse will reset and power will be restored after a short time. If the thermal fuse trips repeatedly during normal use, the vehicle may need repair.

⚠ WARNING: DO NOT BYPASS THE FUSE - RISK OF FIRE. This may overload and damage the electrical system.

Battery Re-charge Interval and Time

IMPORTANT!

Check the drive battery and charger (supply cord, connector) for wear and damage before charging. Do not charge the battery if damage has occurred. Only replace with the same type and voltage rechargeable battery and charger supplied by the manufacturer.

- Only use the rechargeable battery (or equivalent replacement) and charger supplied with your vehicle.
- Before first use, charge battery **8 to 12 hours - never longer than 20 hours.**
- Once battery is depleted, recharge for **8 to 12 hours - never longer than 20 hours.**
- Do not short circuit the battery: Do NOT connect red and black wires together or connect positive and negative terminals on the battery together.
- When battery is fully charged, un-plug charger from the wall outlet and disconnect from charger port.

The drive battery should be charged when depleted, or if not used regularly, once a month. Failure to charge the battery as directed will cause permanent damage to the battery and will void the warranty.

Drive Battery Replacement:

STEPS:

1. Turn Scooter on it's Side.
2. Remove the Battery Cover and Screws (B).
3. Remove the Battery Bracket and Screws (C).
4. Disconnect the Red and Black Battery Terminals (D).
5. Carefully remove the Battery.
 - Depending on the condition of the battery (leakage or damage) you may want to wear protective rubber gloves before removal.
 - Do not lift the battery by its connectors or cables.
6. Place the dead battery in a plastic bag.
7. Install replacement battery and reconnect the connectors: Red to Red Terminal, Black to Black Terminal.
8. Replace the battery bracket (C).
9. Replace the Battery Cover (B).

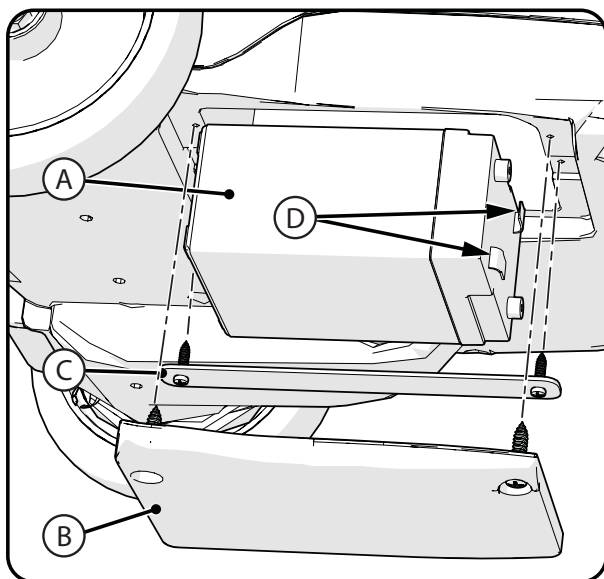

NOTE: The Thermal Fuse is attached to the red power wire and resets if Battery is overloaded.

Battery Storage and Disposal

The drive battery should be charged when depleted, or if not used regularly, once a month. Failure to charge the battery as directed will cause permanent damage to the battery and will void the warranty.

Follow these guidelines if the battery is removed:

- Do not store battery in extreme hot or cold temperatures.
- Wipe the battery clean with a dry cloth prior to storage. Wash cloth separate from other clothes.

BATTERY DISPOSAL:

- The sealed lead-acid battery must be re-

cycled or disposed of in an environmentally sound manner.

- Do not dispose of battery in a fire. The battery may explode or leak acid.
- Do not dispose of the battery in household trash. The incineration, land filling or mixing of sealed lead-acid batteries with household trash is prohibited by law.
- Return an exhausted battery to a federal or state approved lead-acid battery recycler, such as a local seller of automotive batteries (check local battery disposal regulations).

Parts List

#	Description	#	Description
1	Grips (x2)	11	Battery
2	Handlebar Assembly	12	Battery Brace
3	Head Cover w/Screws	13	Battery Cover w/Screws
4	Handlebar Clamp w/Hardware	14	Locknut (x2)
5	Head Set bushings	15	Washer (x2)
6	Axle Threaded Screw Set	16	Right Rear Wheel (non-drive)
7	Fork Threaded Screw Set	17	Left Drive Wheel
8	Fork	18	Rear Axle
9	Fender	19	Body/Frame Assembly
10	Front Wheel		• with motor and Bubble blower
		20	Charger

Introduction to Assembly

This Owner's Manual may be made for several different style products.

- Some illustrations may vary slightly from the actual product.
- Follow instructions completely.
- If the product has any parts that are not described in this manual, look for separate "Special Instructions" that are supplied with the unit.
- All features, components and accessories are not included on all models.
- Use the Index page to locate specific sections of this manual.
- Please read through this entire manual before beginning assembly or maintenance.
- If you are not confident with assembling this unit, contact customer service.

⚠ WARNING: Keep small parts away from children during assembly.

NOTE: All of the directions (right, left, front, rear, etc.) in this manual are as seen by the rider while seated.

Do not dispose of the carton and packaging until you complete the assembly of the product. This can prevent accidentally discarding parts of the unit.

Tools Needed (supplied)

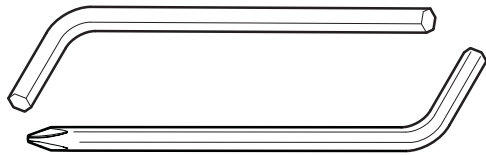

Allen/Phillips Wrenches

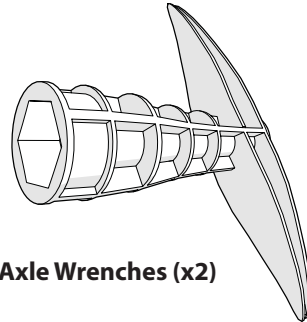

T-Axle Wrenches (x2)

CHARGING PORT LOCATION:

NOTE: Charging Port **(A)** is located on the front LEFT side of the deck, next to the Bubble ON/OFF switch **(B)**.

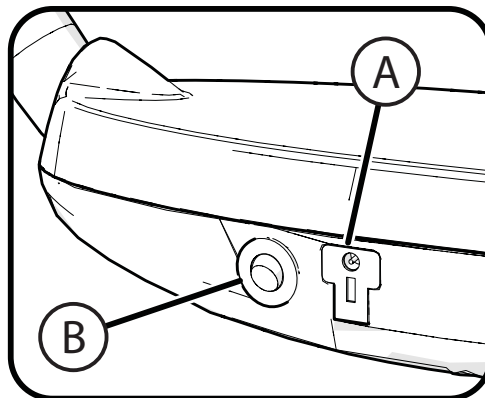

Maintenance Repair and Service

GENERAL: The vehicle should be checked for damage, missing or badly worn parts before each use. If any part of the product does not operate properly – discontinue use.

- Check the tightness of the fasteners before each use. Replace any fasteners that are damaged.
- Inspect the product frequently. Failure to inspect the product and to make repairs or adjustments, as necessary, can result in injury to the rider or to others. Make sure all parts are correctly assembled and adjusted as written in this manual and any "Special Instructions".
- Immediately replace any damaged, missing, or badly worn parts.
- Make sure all fasteners are correctly tightened as written in this manual and any "Special Instructions". Parts that are not tight enough can be lost or operate poorly. Over tightened parts can be damaged. Make sure any replacement fasteners are the correct size and

type.

- Check the tightness of the wheels:
- NOTE:** If the drive wheel is not tight, it will not engage the gears and the vehicle will not run.
- Ensure the battery bracket is securely in place before use.
- Store the vehicle indoors. Keep it away from sources of heat, such as stoves and heaters.
- Keep the product clean and free of dirt, dust and water. This will prolong the useful life of the product.
- Clean the vehicle with a soft, dry cloth. To restore shine to plastic parts, use a non-wax furniture polish. Do not use automotive wax, abrasive cleaners or wash the vehicle with soap and water.

NOTE: If the instructions in this manual or any "Special Instructions" are not sufficient for you, please contact customer service.

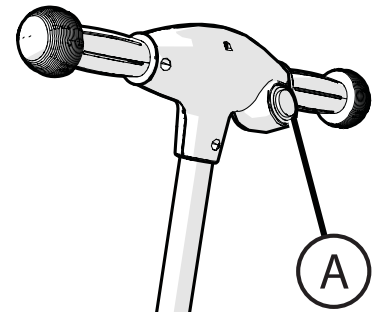
Operation:**USAGE:**

- Turn ON Scooter power by holding down Power Button (A). Release Power Button to stop.
- Push Motor Engage-Lever (B) DOWN to engage motor and UP to disengage motor.

NOTE: Disengaging Motor allows scooter to be self-propelled.

TO USE BUBBLE MAKER:

CAUTION: Fill ONLY with solution designated on the product:

- Pull out Fill Tray (C) as shown (**Drawer is not removable**), to fill with Bubble solution. **Do Not Overfill.**
- Turn Switch (D) ON to activate Bubble feature when pressing Power Button (A).
(E) is Bubble outlet - Keep clean and free of debris.

NOTE: With Motor disengaged, Bubble feature will continue to function if Switch (D) is turned ON.

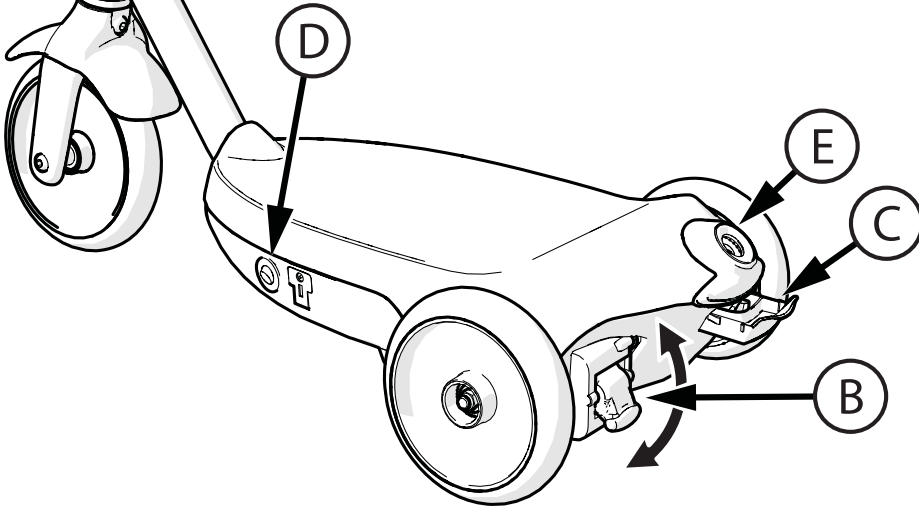
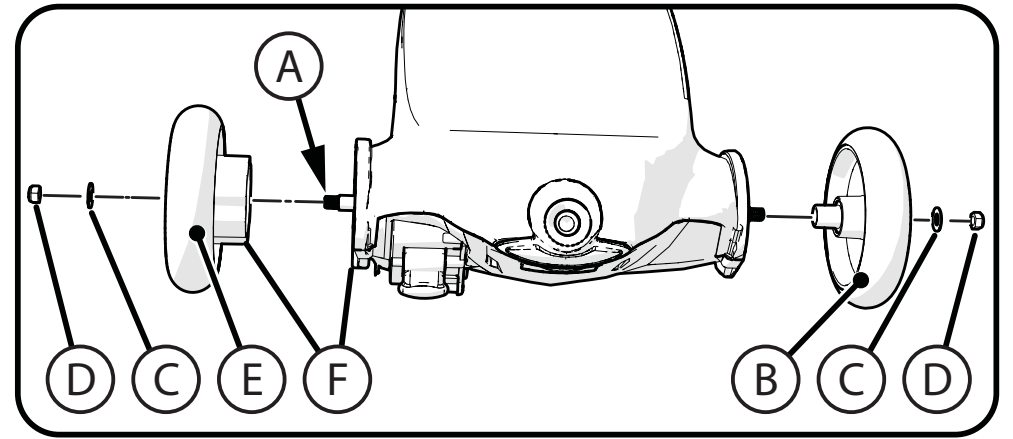
**Installing Rear Wheels:****STEPS:**

1. Insert Rear Axle (A) through Body as shown.
2. Install right rear Wheel (B), one Washer (C) and one Locknut (D) onto Axle.
3. Install Drive Wheel (E) onto Axle so that Drive Gear (F) fits into Drive Motor.
4. Install Washer (C) and Locknut (D).
5. Tighten both Locknuts fully and securely.

WARNING: Both hands must firmly grip the handlebar before pushing Power Button (A). Failure to follow this rule can result in personal injury or damage to the product.

Assembling the Front Wheel and Handlebar:

STEPS:

1. Ensure Power Button **A** and Wiring Connector **B** are facing BACK.
2. Insert Steering Rod **C** down through Neck frame.
3. Ensure top and bottom Neck Bushings **D** are fully inserted into Neck frame and sit fully in Notches **E**.
4. Place Fender **F** over Fork Assembly **G**.
5. Insert this Fork Assembly up onto Steering Rod **C** fully so that Fork mounting holes line up.
6. Install Fork Screw Set **H** through Fork assembly and Steering Rod. Tighten securely.
7. With Front Wheel on the ground, tighten Clamp **I** securely.

NOTE: Ensure there is approx. **1/16" (1.5mm)** gap between Clamp **I** and top Bushing **D** as shown in view **J**.

NOTE: Ensure Handlebar turns freely from left to right until it hits the turn stops.

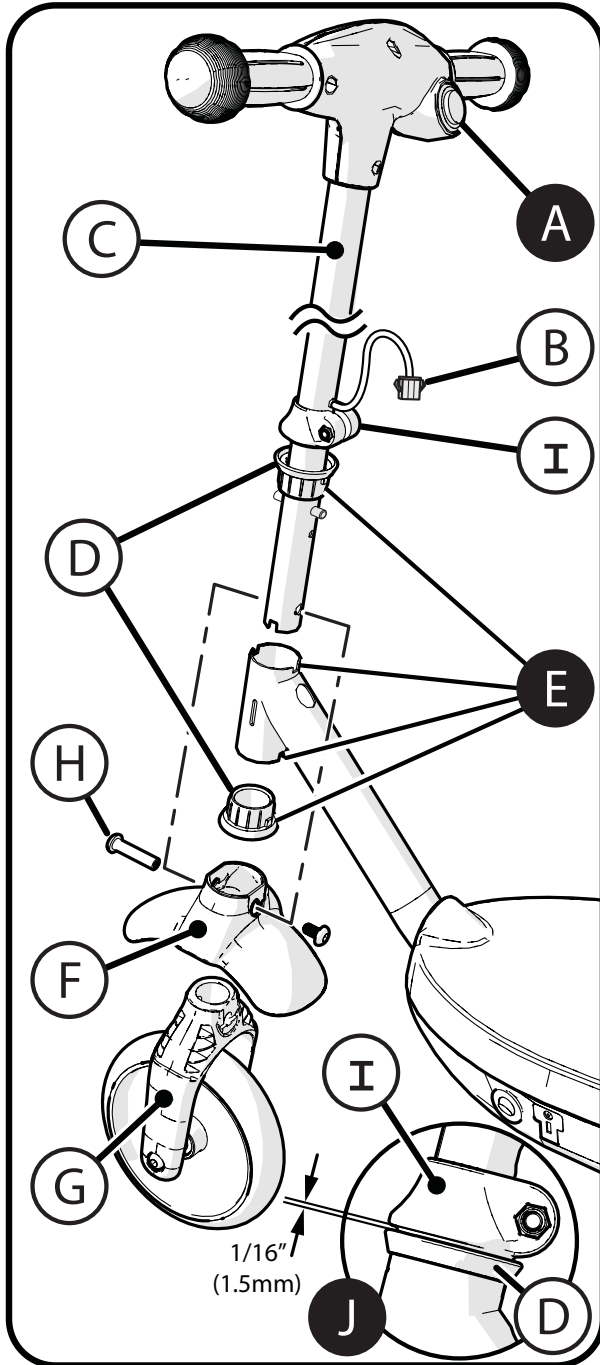

PROCEED TO NEXT STEP >>

Handlebar Connectors and Clamp Cover Assembly:

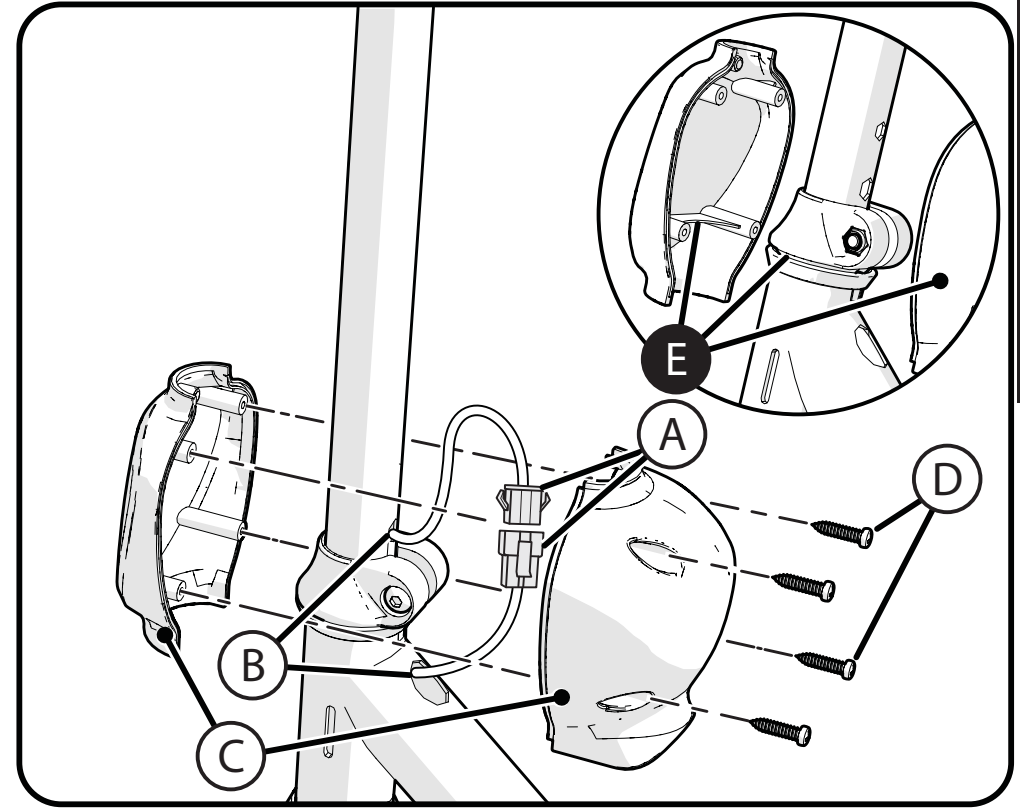

STEPS: (TIP: Hand start screws **D** before assembly)

1. Connect Power Plugs **A** firmly and completely.
2. Tuck excess wire into Wire Slots **B** - **Check that Handlebar and fork turn fully from left to right and that Wires are not pinched or stretched.**
3. Place Clamp Covers **C** around Steering Tube Clamp

NOTE: Ensure Clamp Supports fit **INSIDE** Clamp gap as shown in view **E**.

4. Install 4 Screws **D** securely - Ensure Connector Wires are not pinched.

NOTE: Make sure Handlebar and Fork turn easily and completely from left to right.